

Dear Parents,

Please find below the timetable of home learning for the week beginning 15.6.20. Our topic for this week is 'Ourselves'. Please continue to share the wonderful learning on Tapestry with us. Thank you for your continued support ☺

<p>Monday AM Maths - Can you identify the 2D and 3D shapes? Can you find any of these around your house?</p>	<p>Tuesday AM Maths - Make your own 3D shape alien using the nets provided. Which shape have you made? How many faces/vertices/edges does it have?</p>	<p>Wednesday AM Literacy - All about me - prepare a poster all about you to inform your future teacher some information about yourself! You could tell them your favourite things from this year.</p>	<p>Thursday AM U+W - Can you complete the photo challenge? See how many you can tick off!</p>	<p>Friday AM EAD - Make a self-portrait. Use a mirror to look at your features, draw yourself first and then paint or colour it in.</p>
<p>Monday PM Phonics - Cut out the snake's body and put it together to build a phase 4 word.</p>	<p>Tuesday PM Phonics - Read the sentence on the card and match it to the picture to create a loop.</p>	<p>Wednesday PM Phonics - Use the 'Dragon's Den' game to revise all phase 4 words. Feed the green dragon real words and the red dragon pseudo-words. https://www.phonicsplay.co.uk/resources/phase/4/dragons-den</p>	<p>Thursday PM Phonics - Read the word and find the matching picture. Cut it out and stick it in the correct place.</p>	<p>Friday PM Phonics - Use the game to revise reading phase 3 phonemes in words. https://www.ictgames.com/mobilePage/helpAHedgehog/index.html</p>

Further challenge ideas linked to this week's learning:

Physical Development:







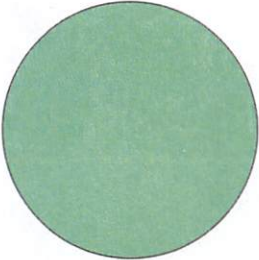

- Can you host your own sports day? What events will you have? Egg and spoon race?
- Complete a 5 minute exercise and observe the effects it has on your body. How has your heart rate or breathing changed?

Personal, Social, Emotional Development:

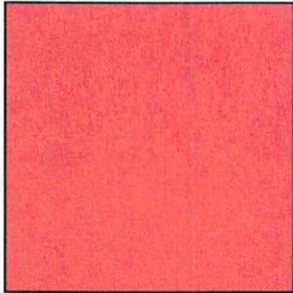
- Talk about healthy choices. What foods or habits are good for maintaining a healthy life style?

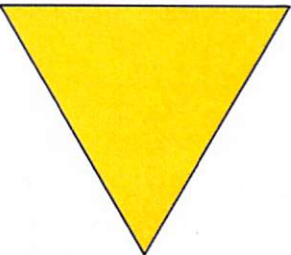
Identify 2D and 3D shapes

Using the word bank, write the correct name of each 2D and 3D shape below.

circle

rectangle

triangle

cube

square

rectangular
prism

cone

sphere

Monday PM

Phase 4 Decodable Words Snake Jigsaws

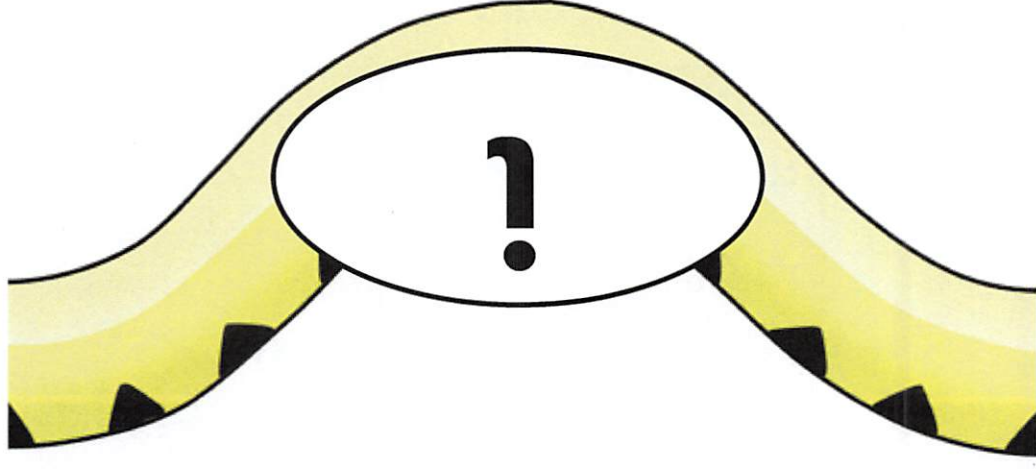
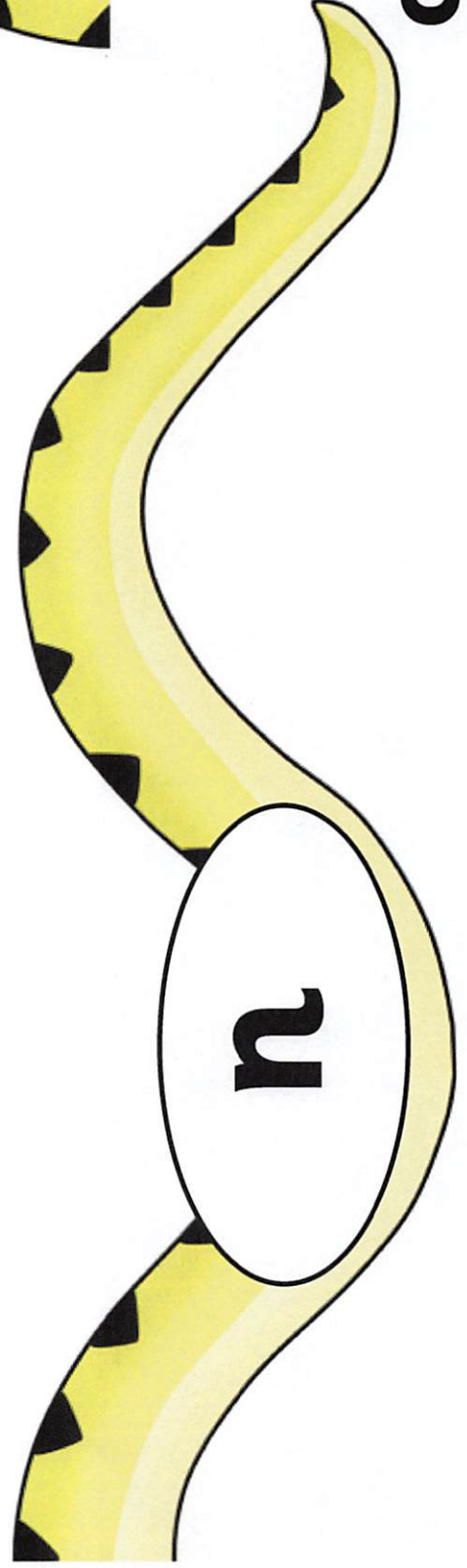
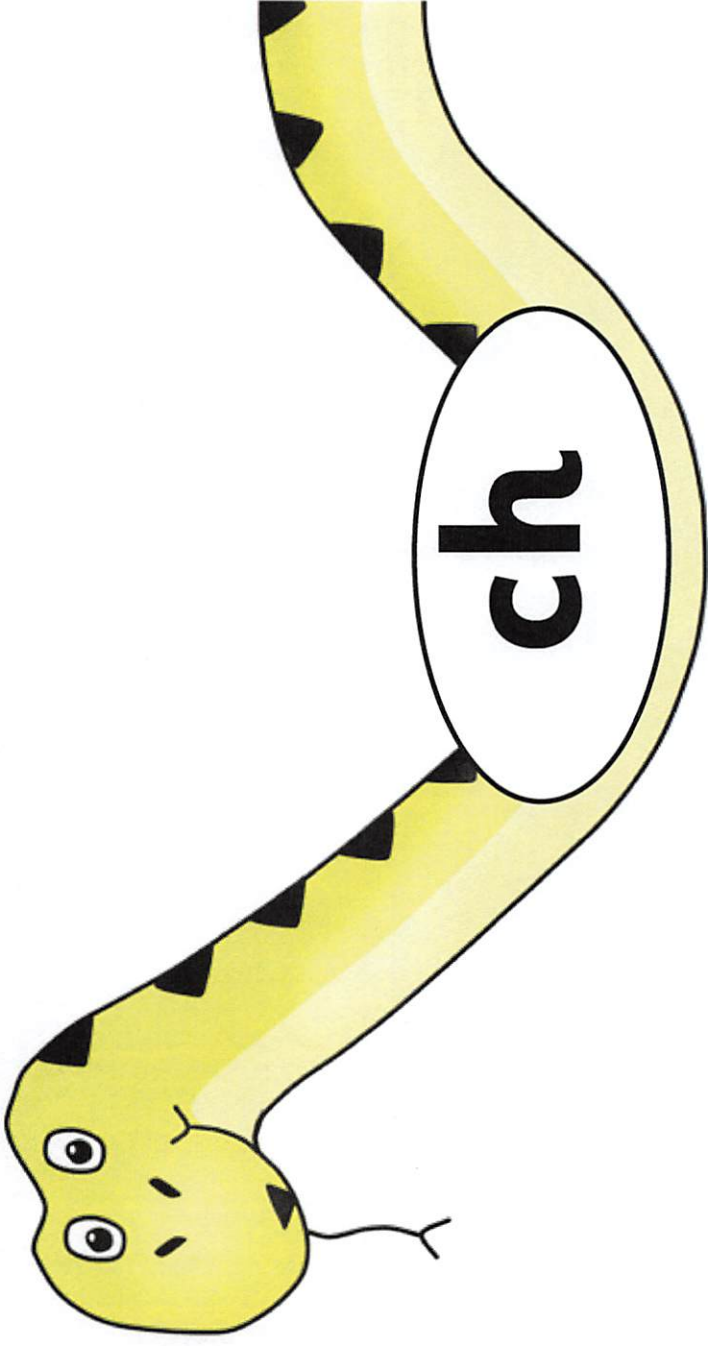

children

Phase 4 Decodable Words Snake Jigsaws

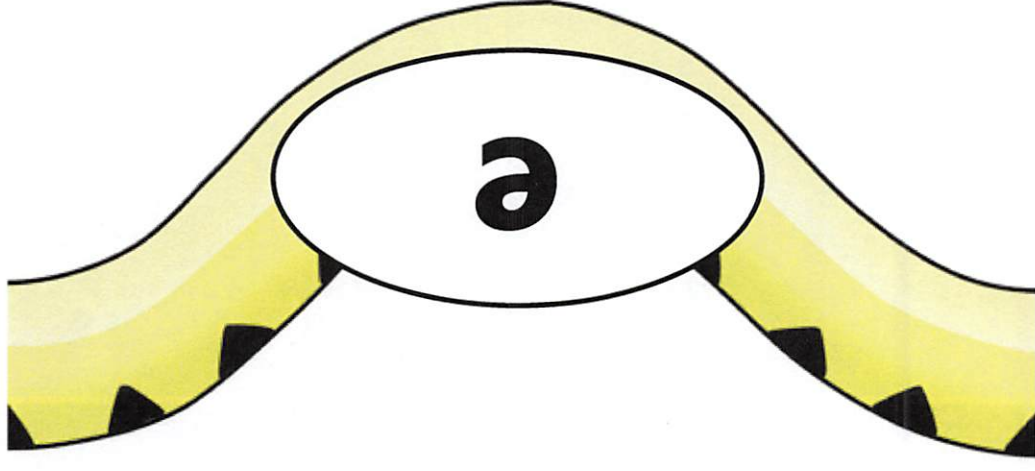
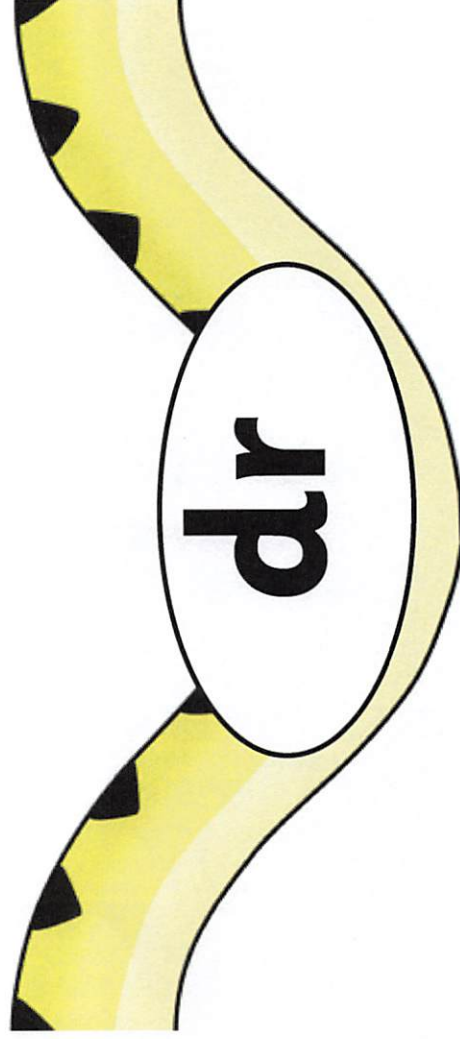
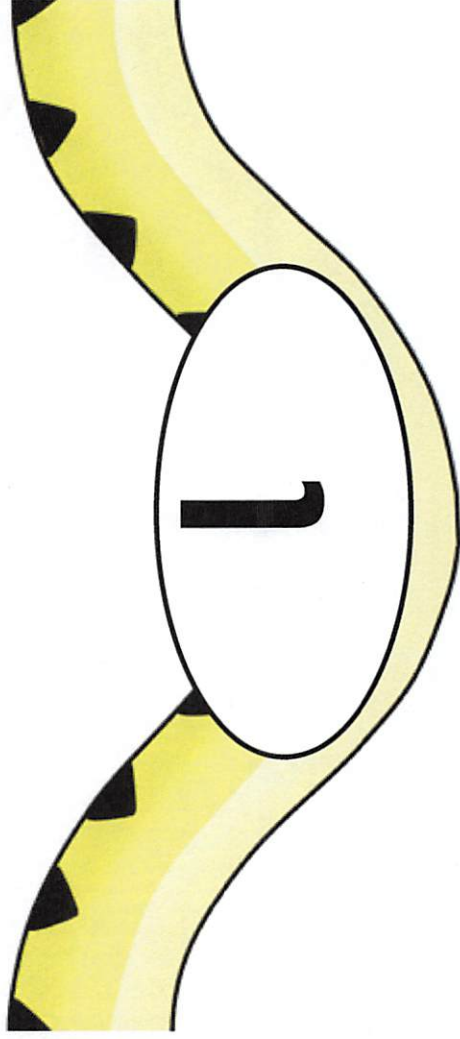

children

Phase 4 Decodable Words Snake Jigsaws

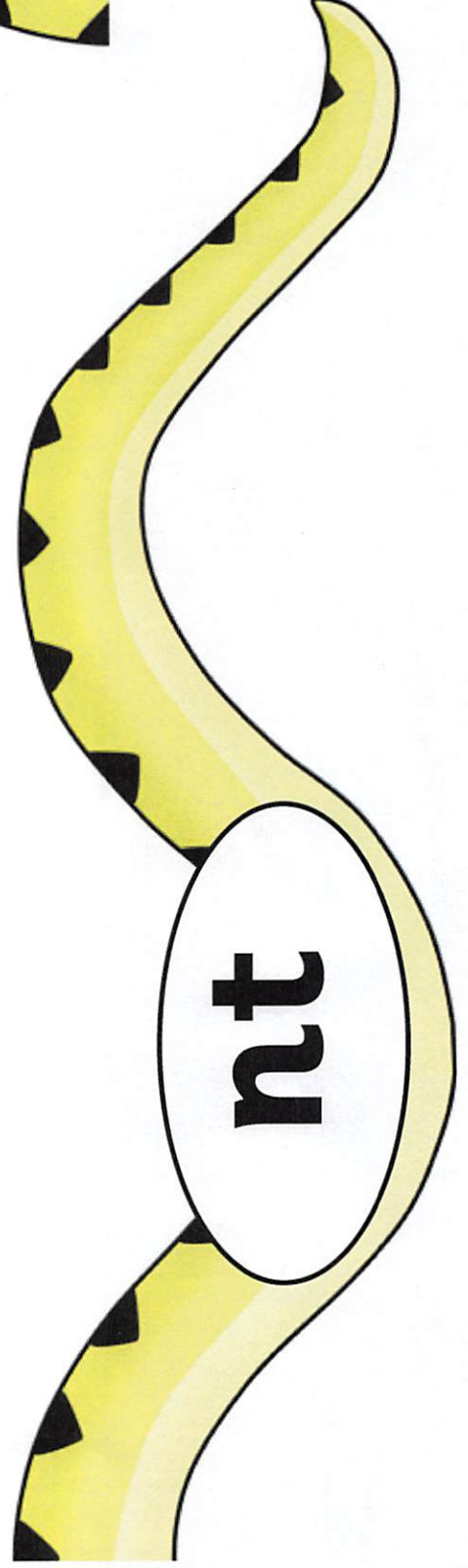
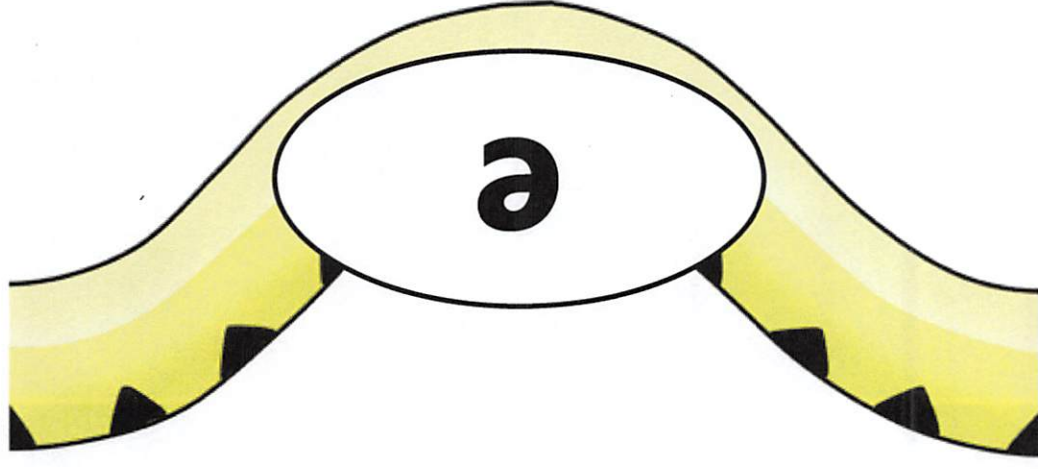
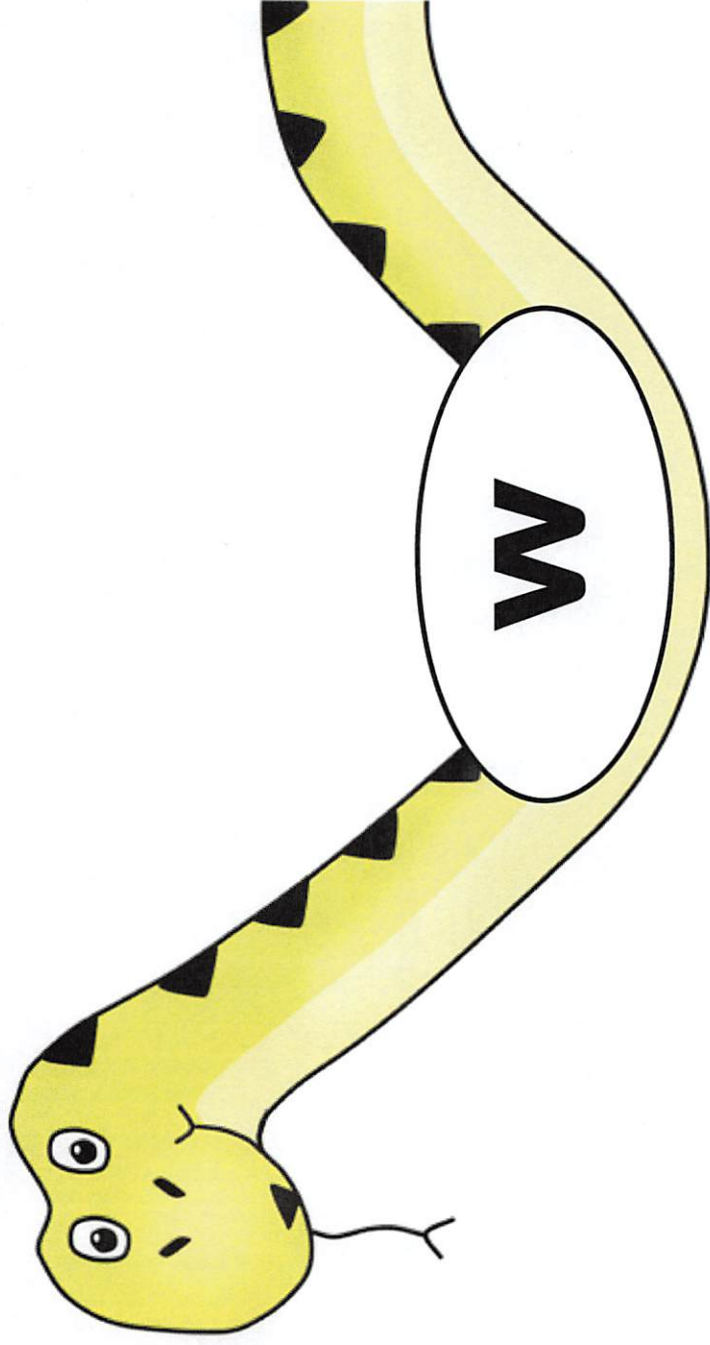

went

Phase 4 Decodable Words Snake Jigsaws

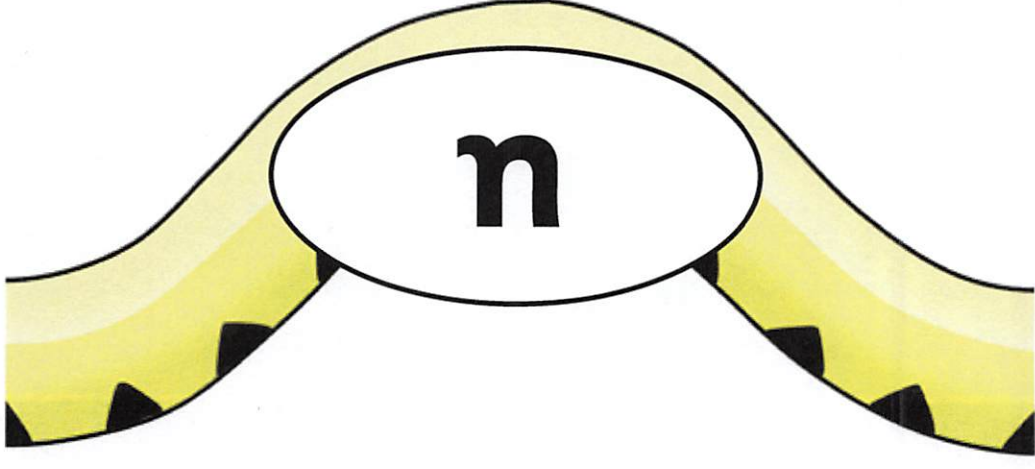
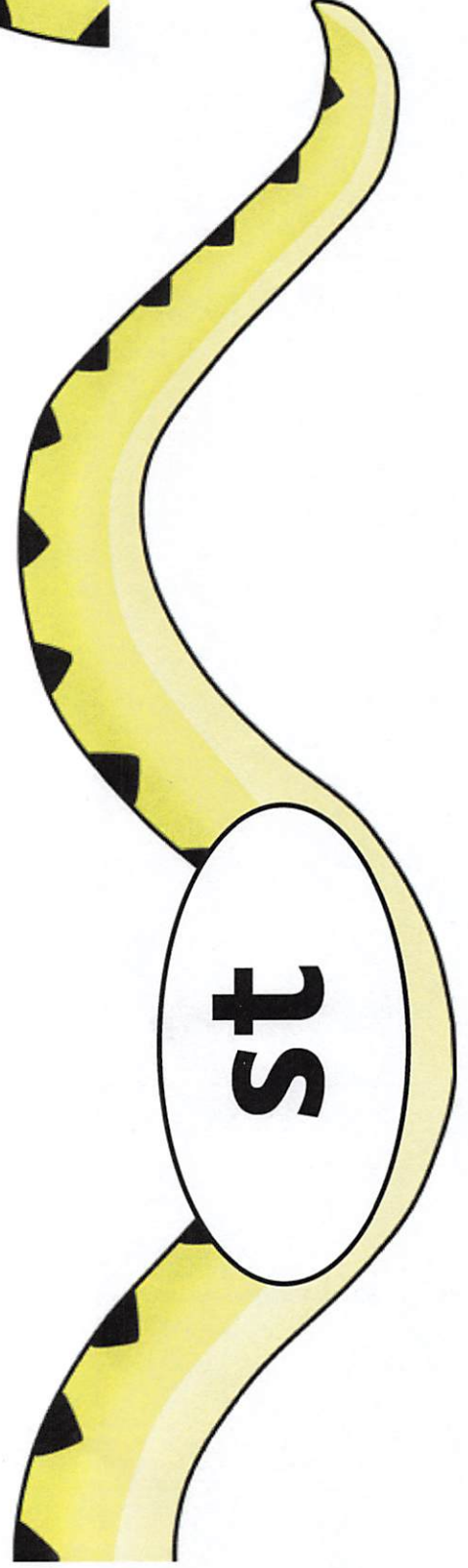
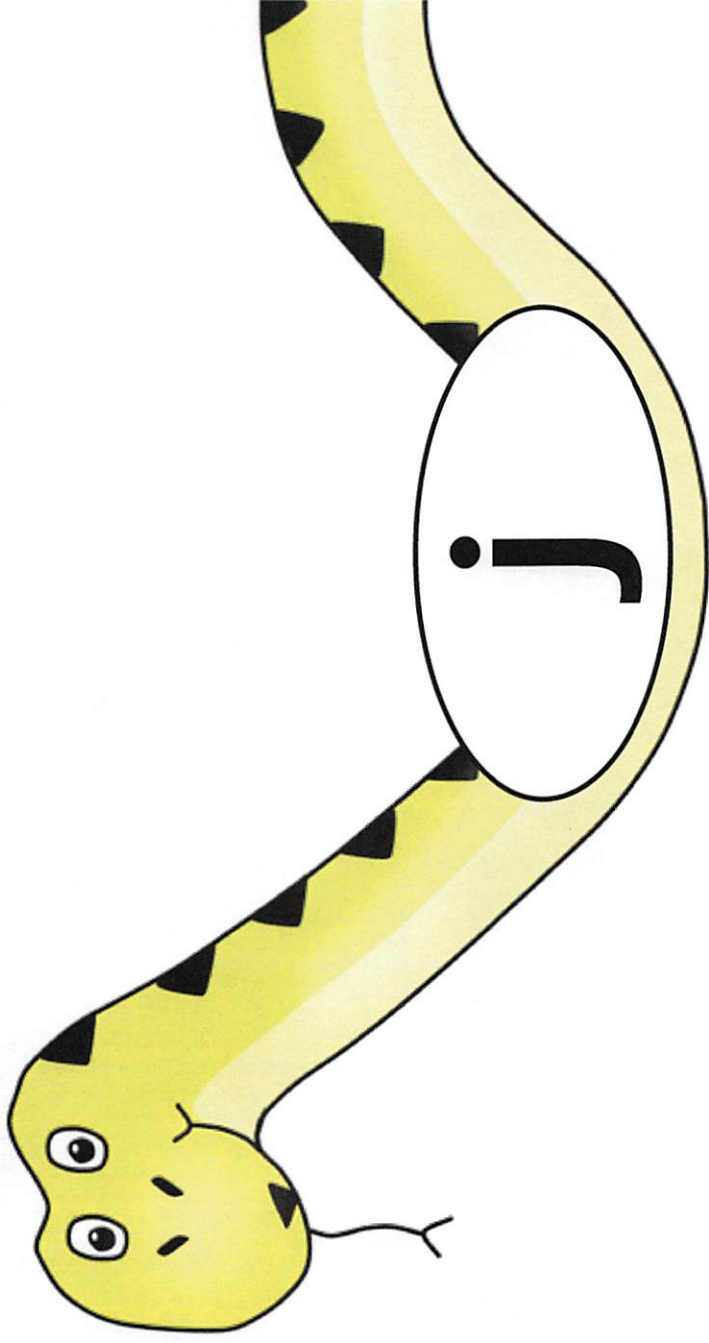

just

Tuesday AM
Alien Cuboid

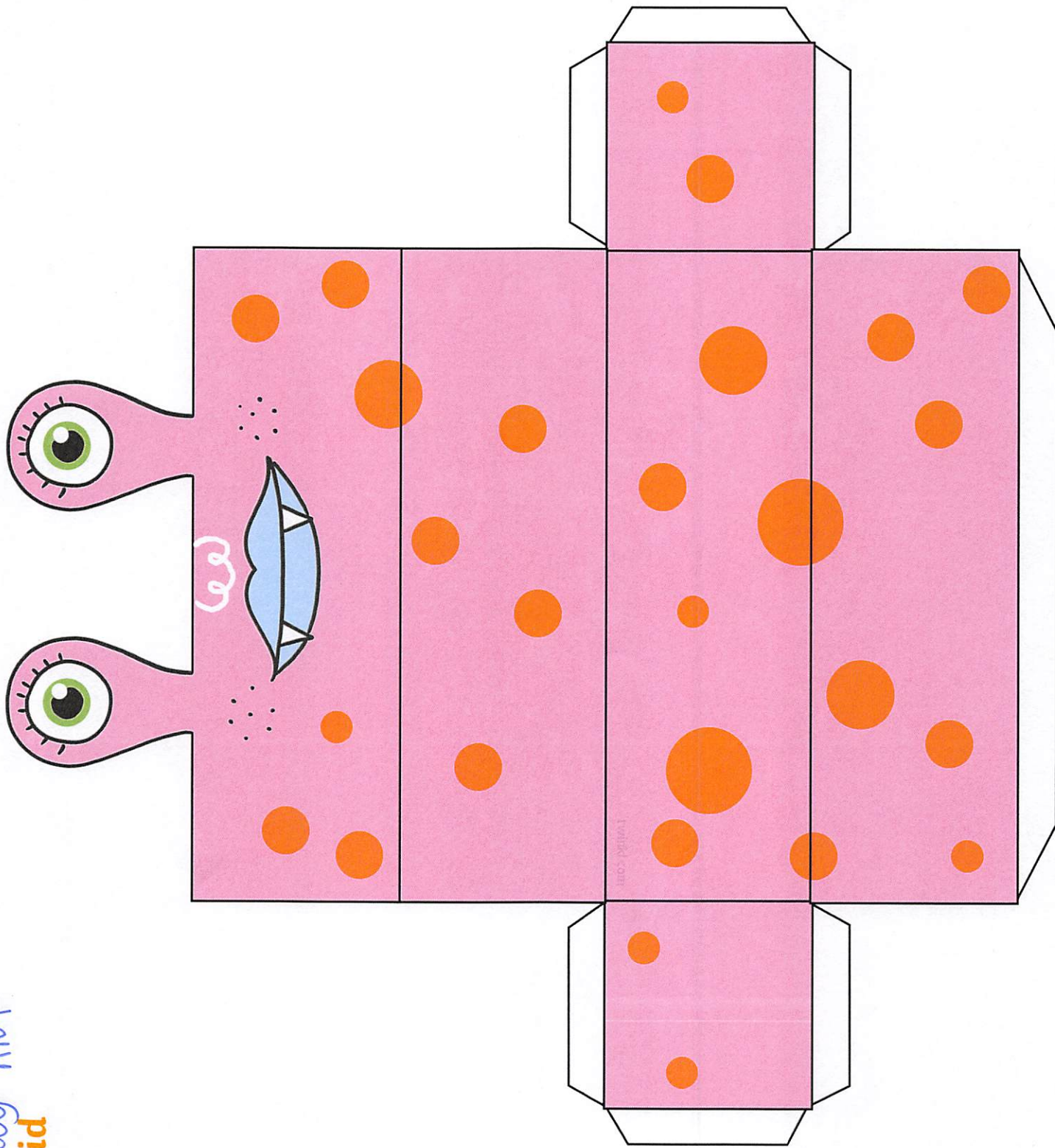

Alien Pyramid

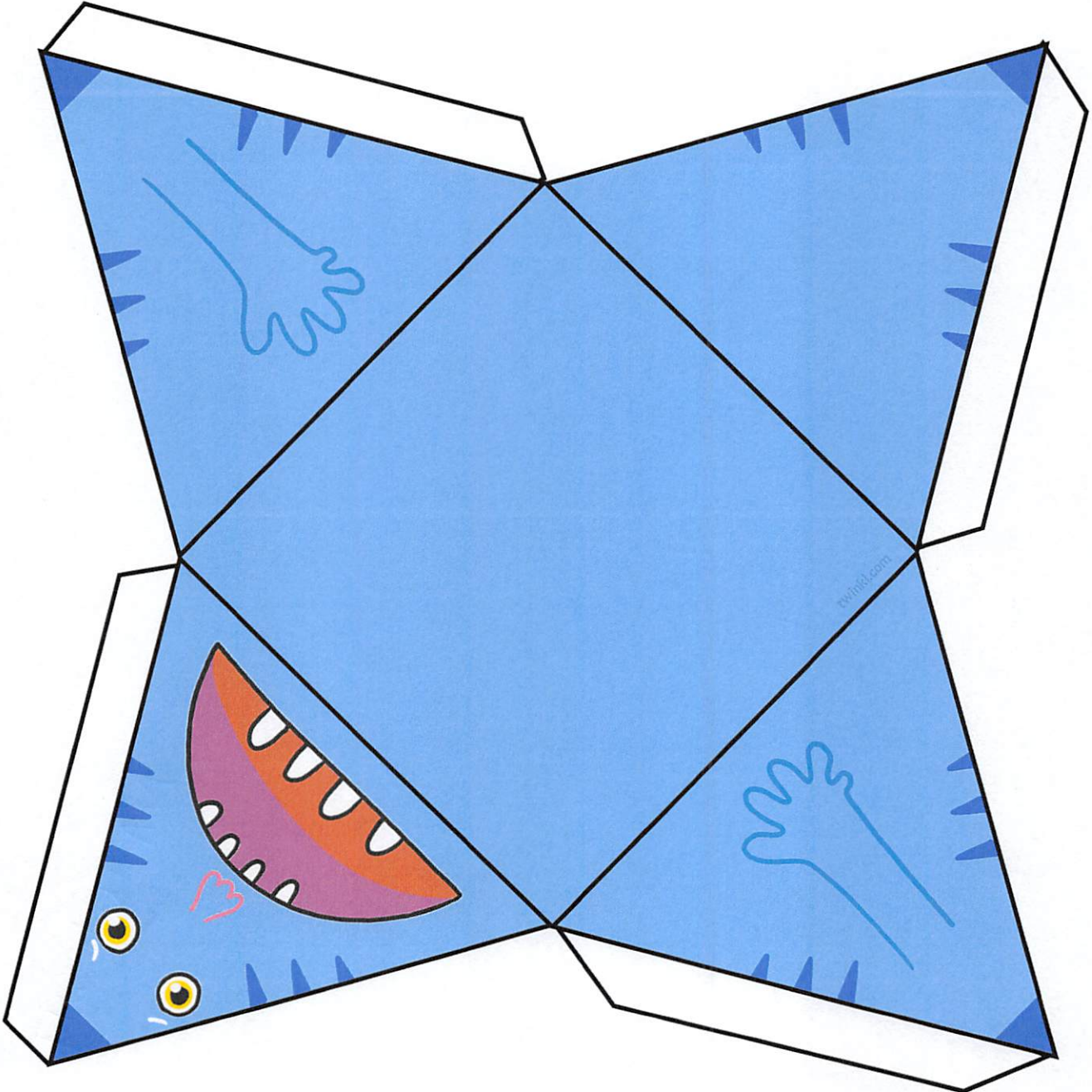

Alien Cube

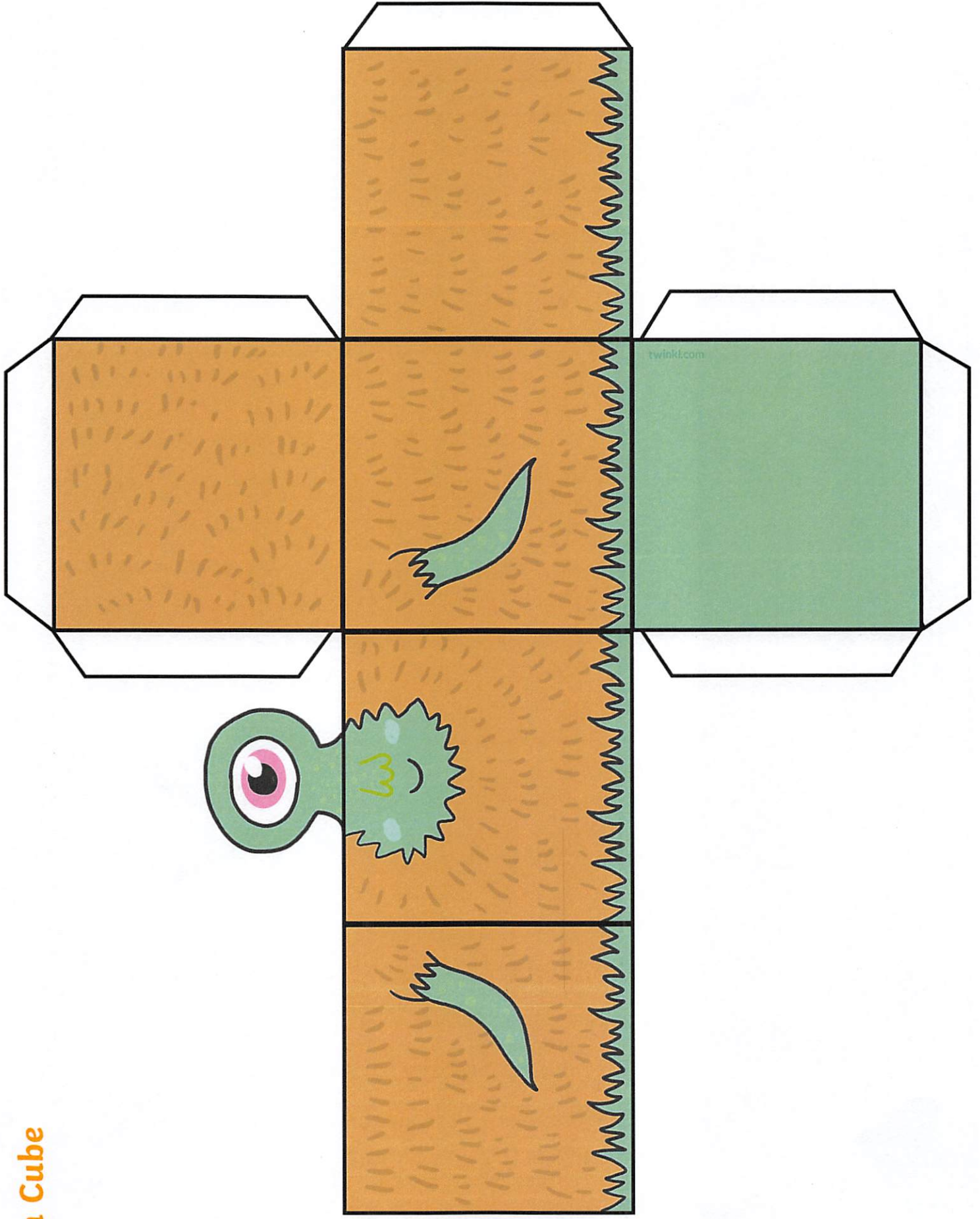

Tuesday PM

Phase 4 pictures and sentences loop cards



GO!

Fred and Brent spent a week in Spain.



I kept bumping into things in the dark.



Milk is good for children's teeth.



The clown did tricks with a chimpanzee.

Phase 4 pictures and sentences loop cards

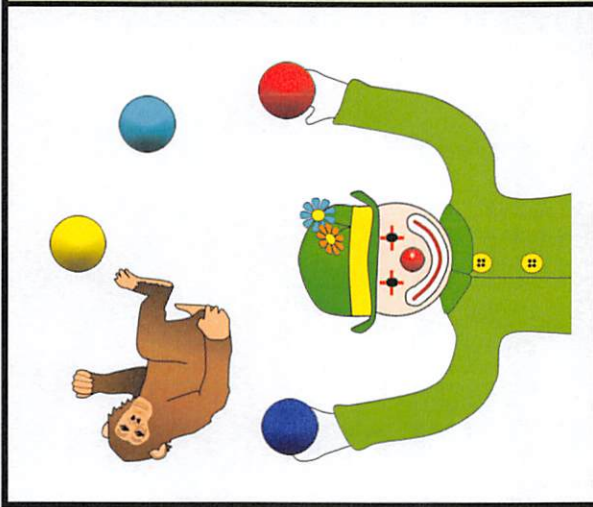

The frog jumps
in the pond and
swims off.



I must not tramp
on the flowers.



A crab crept into
a crack in the
rock.

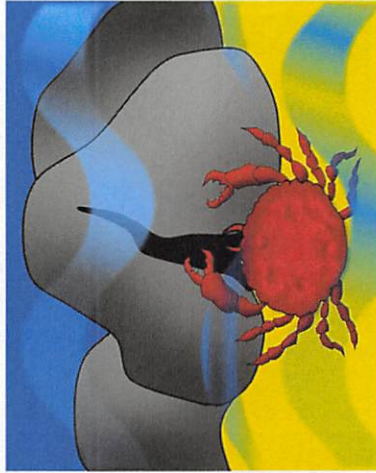

A drip from
the tap drops
in the sink.

Phase 4 pictures and sentences loop cards

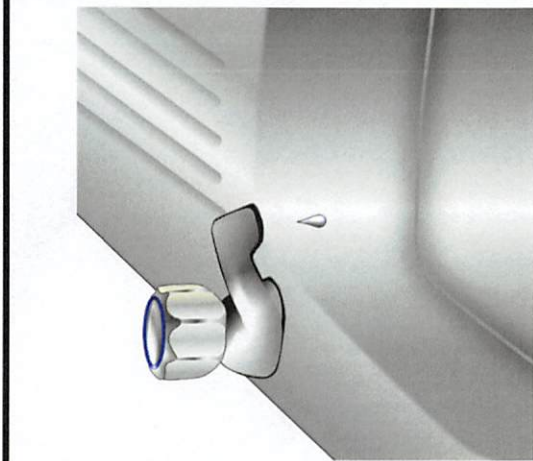

I can hear twigs
snapping in
the wind.

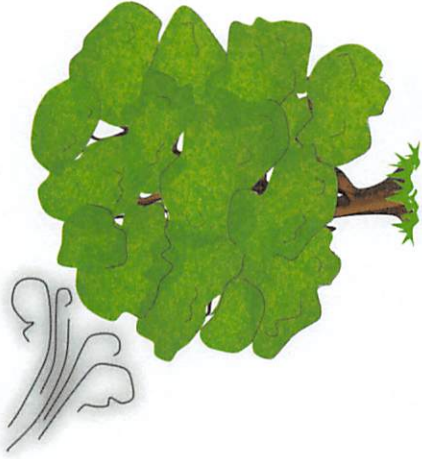

It is fun to
camp in
a tent.

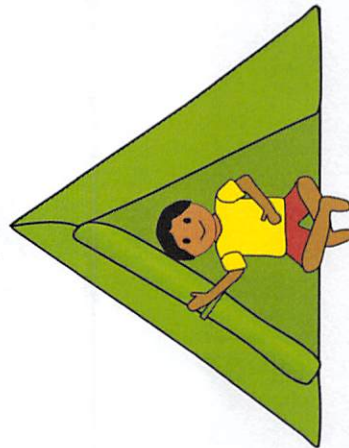

STOP!

Wednesday AM

My favourite activity at school

My favourite food

My friends

My favourite toy

My family

Fill in about me

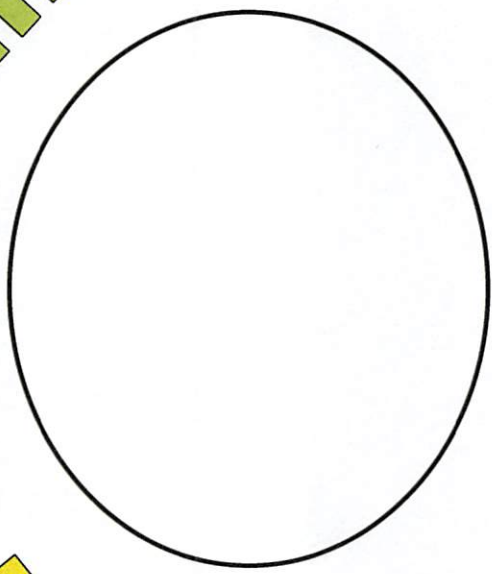

My favourite colour

Name _____

Age _____

Thursday AM

Reception photo challenge!

How many can you tick off?

Take a photo of...

- ✓ Something in nature
- ✓ Your favourite food
- ✓ A member of your family
- ✓ Your favourite toy
- ✓ Where you live
- ✓ An animal
- ✓ A number
- ✓ A letter
- ✓ Your favourite book
- ✓ The weather
- ✓ A mode of transport
- ✓ A view from a window
- ✓ A shape
- ✓ A pattern
- ✓ Something old
- ✓ Something new
- ✓ Something messy
- ✓ Something silly!

Thursday PM

Phase 4 Polysyllabic Words

I Can Read!

children

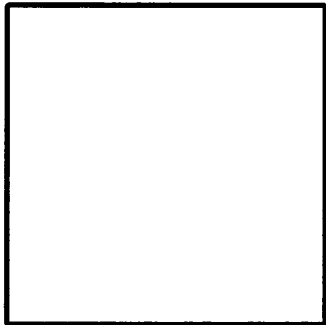

sandpit

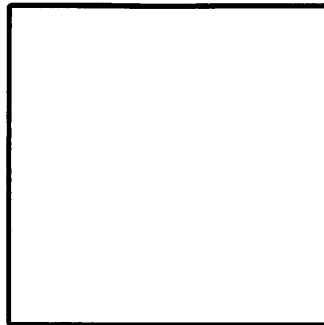

windmill

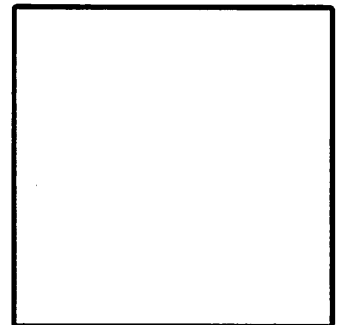

pondweed

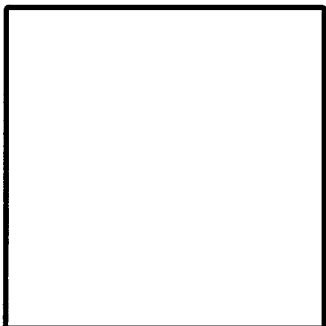

desktop

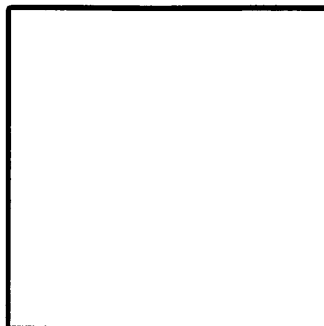

helper

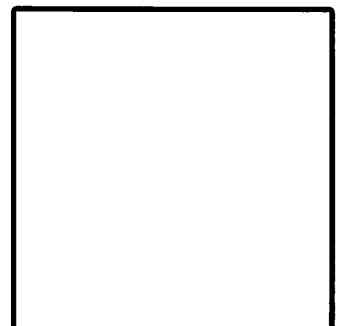

Read the words and match the picture to the word.

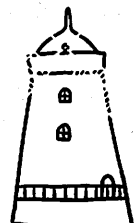
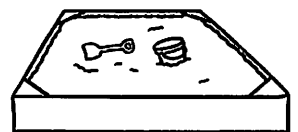
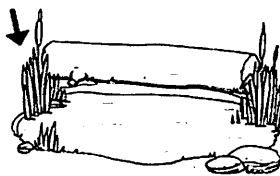

Phase 4 Polysyllabic Words

I Can Read!

handstand

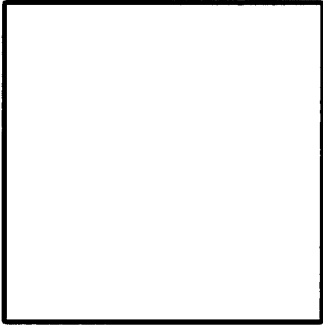

melting

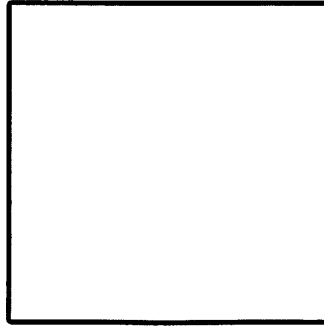

lunchbox

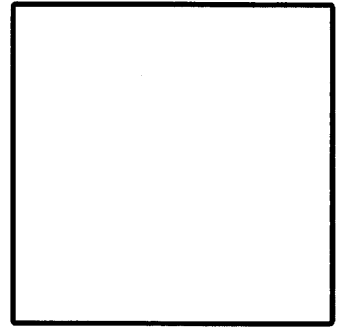

shampoo

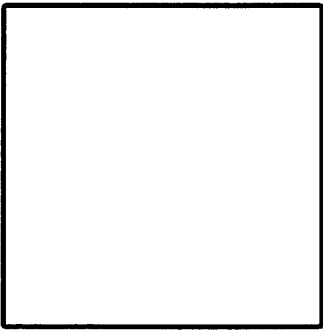

giftbox

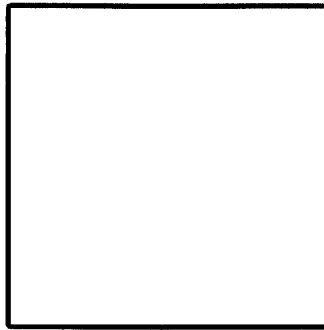

shelter

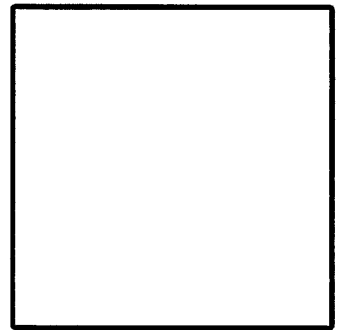

Read the words and match the picture to the word.

